

Development of Multi-axis Servo Amplifier “SANMOTION R” Series

Izumi Yui Tsuyoshi Kobayashi Yoshiyuki Murata Tetsuya Hayashi
Takao Oshimori Akihiro Matsumoto

1. Introduction

The AC servo amplifier “SANMOTION R” that went on sale in 2004 has been well received by the market due to its high performance and extensive features. At the same time, it is true that the market is demanding a much smaller servo amplifier with less wiring.

To respond to such market demands, we developed the multi-axis servo amplifier “SANMOTION R” series that has smaller footprint with less wiring while maintaining the high performance and extensive features of the AC servo amplifier “SANMOTION R”. This document describes the features of this new product.

2. Product Overview

Servo amplifiers are powered by commercial AC source in the same way as standard electrical equipments. They control the position, speed, and torque of servo motors. Their components can be roughly divided into following segment:

- (1) Converter segment: Converts AC power to DC power.
- (2) Inverter segment: Converts DC power to AC power.
- (3) Control circuit segment: Controls the inverter segment (2).
- (4) Switching power supply segment: Supplies power to the control circuit segment and peripheral circuitry.

In a single axis configuration (one servo amplifier connected to one servo motor), each servo amplifier contains all of the segments indicated above. Depending on the machine tool or robot in which it is used, more than one servo amplifier may be used, in which case it is necessary to supply AC power to each servo amplifier and connect each servo amplifier interface to their superior controllers with cables. As a result, there is a limit to the number of the cables and amount of footprint that can be reduced.

The new servo amplifier system that we developed shares segment (1), segment (4), and the interface connection with the superior controller with other amplifiers, enabling reduction in the installation space and wiring. Fig. 1 shows the exterior view of the new servo amplifier.



Fig. 1: Exterior view of multi-axis servo amplifiers “SANMOTION R” (15 A × 4)

3. Features

With the multi-axis servo amplifier “SANMOTION R” series, in order to reduce its size and wiring, the structure of the servo system is divided into the following three units that can be flexibly combined. Each unit is described in detail in the sections that follow.

- Amplifier unit
- Power source unit
- Motherboard unit

3.1 Amplifier unit

The amplifier unit controls the motor through the inverter from the DC power source provided by the motherboard. The amplifier unit is available in two output capacities, 15 A and 30 A, which users can select according to the capacity of the servo motor to which the amplifier will be connected. The power line from the controlled servo motor and the signal line from the sensor are attached to the connectors located on the front of the amplifier unit.

In addition to these connectors, the front of the amplifier unit is also furnished with an address self-configuration SW, status LED's,

and PC interface connectors, allowing users to easily check the operating status of the amplifier from the front.

The front width of the amplifier unit is 30 mm for the 15 A capacity type and 60 mm for the 30 A capacity type; the 30 A type requires a footprint equal to two 15 A units. Figs. 2 and 3 show the external dimensions for each type.

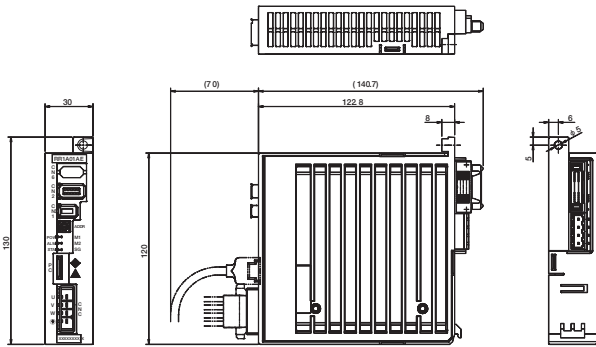

Fig. 2: External dimensions of 15 A amplifier unit

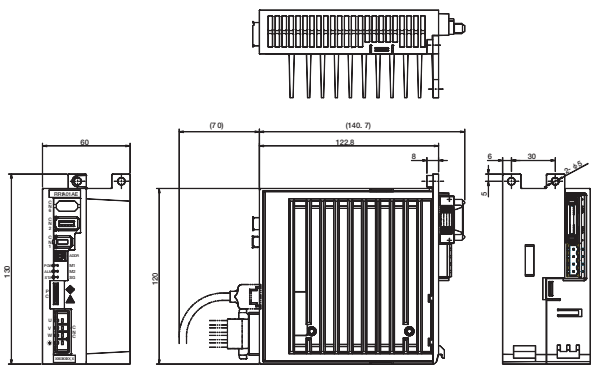

Fig. 3: External dimensions of 30 A amplifier unit

3.2 Power source unit

The power source unit is the input source for AC power to the servo system and also functions as the unit that interfaces the superior controller with the power source unit and the amplifier unit. The input signals to the amplifier unit go through the power source unit and the motherboard unit.

The interface between the upper level controller and the servo amplifier is available in two types: the pulse train input type (position command) and the serial interface type that uses our original communication chip GA1060. Fig. 4 shows the external dimensions of the serial interface type.

3.3 Motherboard unit

The power source unit and the amplifier unit are mounted on the motherboard unit from front. The motherboard is equipped with connectors for these units and the switching power supply circuit.

The motherboard unit is available in three types: 4-slot, 6-slot, and

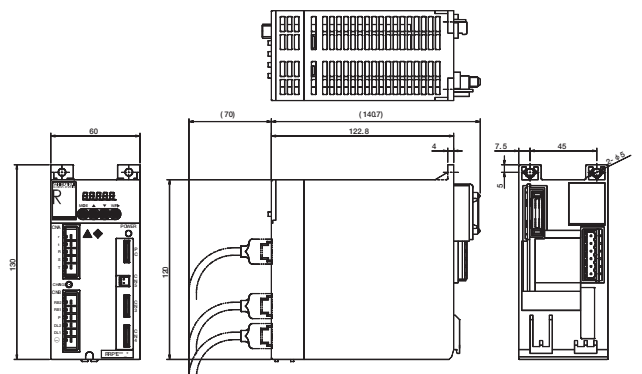

Fig. 4: External dimensions of the power source unit

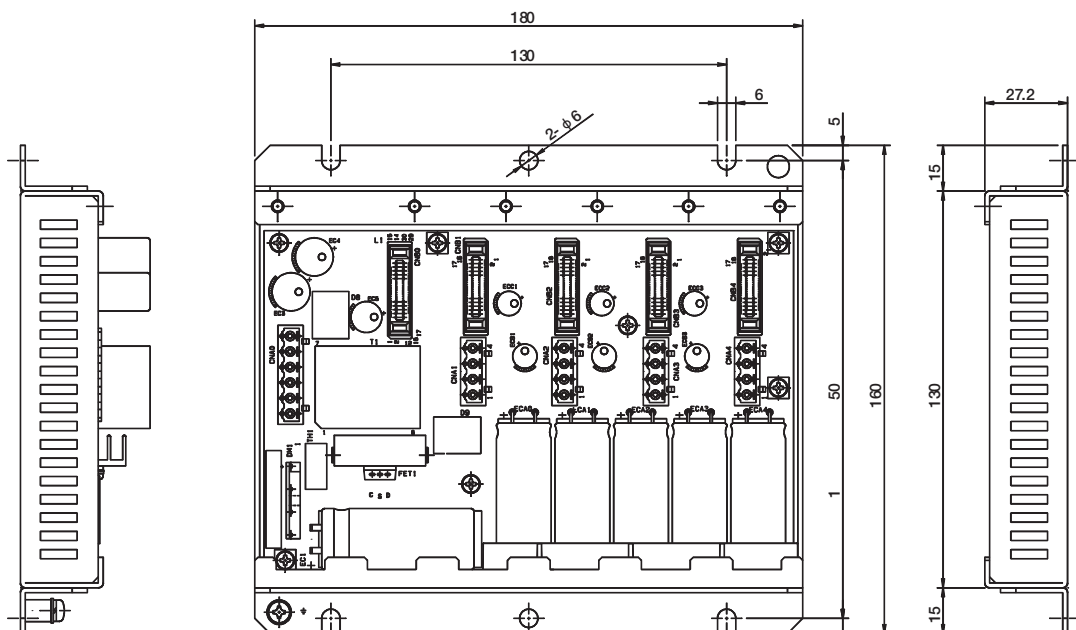

Fig. 5: External dimensions of the motherboard unit (4-slot type)

8-slot types. These slots accommodate the amplifier units. A 15 A type amplifier unit occupies one slot, while a 30 A type occupies two. Please note that due to power circuit constraints, the maximum number of amplifier units that can be installed on the motherboard is six.

3.4 Customer benefits

Fig. 6 shows the block diagram of the multi-axis servo amplifier “SANMOTION R” series. As shown in this diagram, the converter segment, switching power supply section, and user interface segment are shared within the servo system, resulting in simplified wiring, reduced manpower, and enhanced reliability. The footprint can be

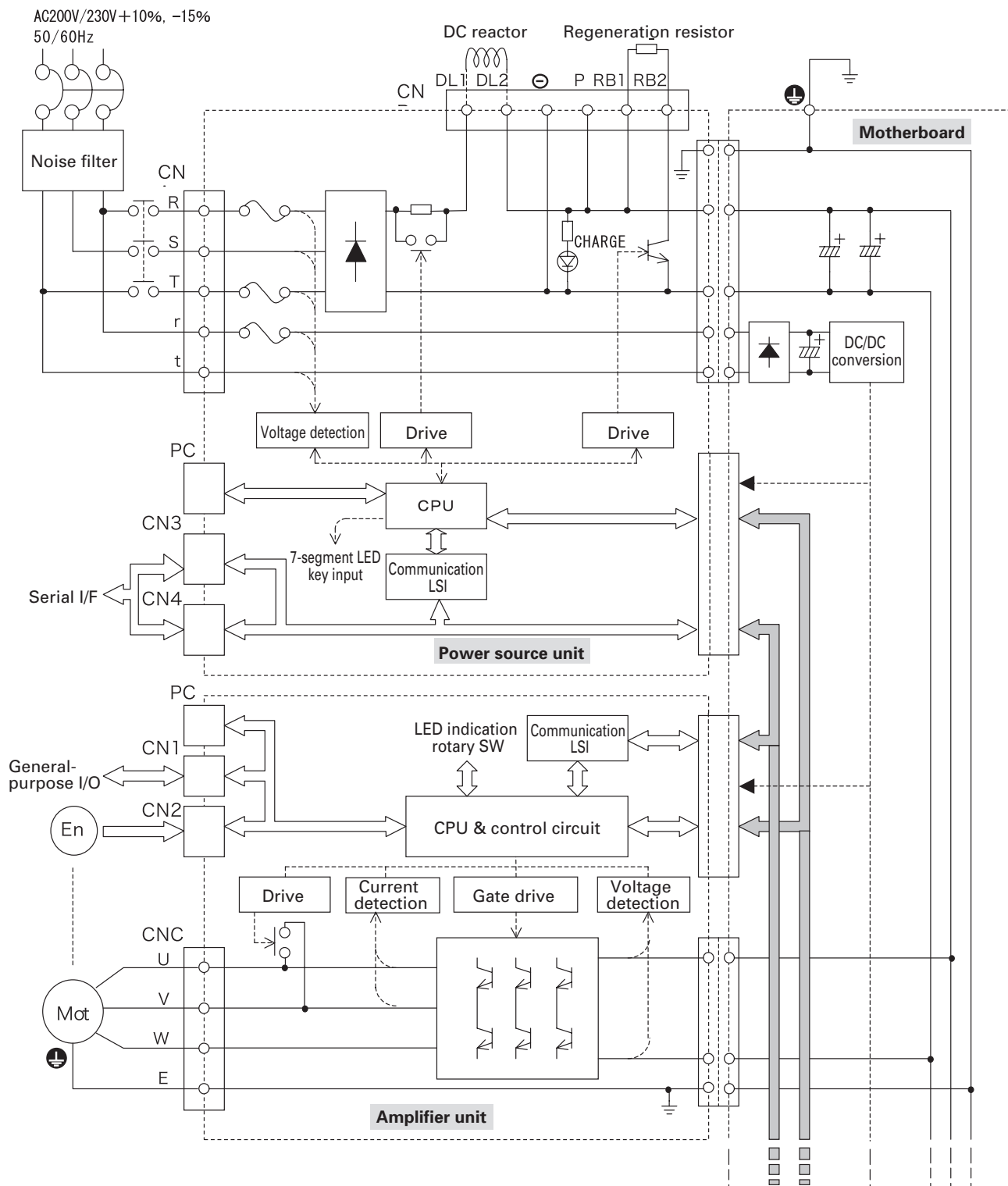

Fig. 6: Block diagram of multi-axis servo amplifier “SANMOTION R”

reduced up to 40% (in 15 A × 6 configuration) compared to lining up single axis servo amplifiers, allowing downsizing of the overall system.

Customers can also benefit from energy saving. Regenerated energy from the servo motor can be used for power running other units since the power source unit is shared among multiple amplifier units.

Please note that with the multi-axis servo amplifier "SANMOTION R" series, the maximum total output of the servo motors that can be connected to each amplifier unit is limited to 2 kW.

4. Conclusion

In this document, we have described some of the features of our new multi-axis servo amplifier "SANMOTION R" series.

This product has a smaller footprint and less wiring compared to our previous products. Therefore, it can fully respond to the increasing demand for miniaturization and space saving features in semiconductor manufacturing equipment and other similar devices.

We will continue to provide wide variations of this product in order to meet the market demands.



Izumi Yui

Joined SanyoDenki in 1986
Servo Systems Division, 2nd Design Dept.
Worked on development and design of servo amplifiers



Tsuyoshi Kobayashi

Joined SanyoDenki in 1990
Servo Systems Division, 2nd Design Dept.
Worked on development and design of servo amplifiers

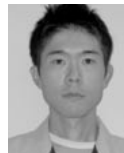

Yoshiyuki Murata

Joined SanyoDenki in 1995
Servo Systems Division, 2nd Design Dept.
Worked on development and design of servo amplifiers



Tetsuya Hayashi

Joined SanyoDenki in 1999
Servo Systems Division, 2nd Design Dept.
Worked on development and design of servo amplifiers



Takao Oshimori

Joined SanyoDenki in 1990
Servo Systems Division, 2nd Design Dept.
Worked on development and design of servo amplifiers

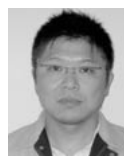

Akihiro Matsumoto

Joined SanyoDenki in 1990
Servo Systems Division, 2nd Design Dept.
Worked on development and design of servo amplifiers